



LI4244RT IMPACTOR TRACK PLANT

The Lippmann 42x44 impactor with the High Energy Screenbox and a recirculating conveyor deliver maximum productivity and unmatched portability. New features include an open chassis for ease-of-access, a larger double deck prescreen for more efficient fines removal, a swing out radial return conveyor that can complete 90 degrees while the machine is running, and a direct drive crusher boosting power and lowering fuel costs.

- 1050mm (41.3") diameter x 1125mm (44.3") wide Impactor
- 360Hp (268kW) Volvo D11 T4 Final engine
- Track or Track c/w Wheel bogie
- Integrated hydraulic folding hopper
- Integrated hydraulic folding stockpiling conveyors
- I-beam plate fabricated chassis construction
- Open chassis design for ease of maintenance
- Fast setup time
- Vibrating feeder under crusher discharge

LI4244RT

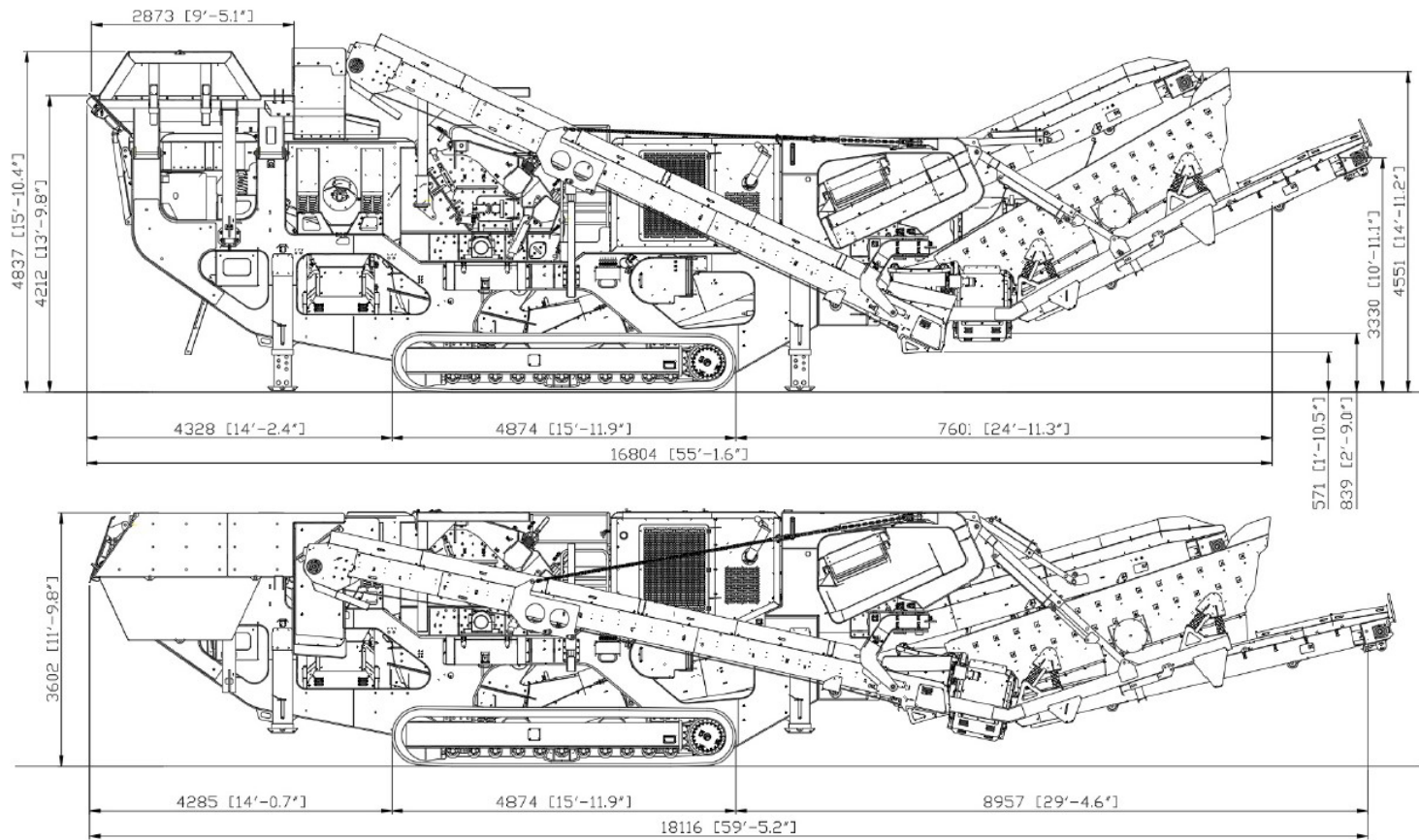

SPECIFICATIONS

Impactor	LI4244	Side Discharge Conveyor	26"	Track	Diesel	D11 Tier 4
RPM	606-740	Discharge Height	8' - 2"	Width	Diesel hp	360
Pan Feeder	42" x 8'	Main Discharge Conveyor	48"	Length	Impactor	Clutch
Maximum RPM	970	Discharge Height	10' - 11"	Height	Feeder	15.6 gpm
Grizzly Pre-Screen	42" x 6'	Screen - Optional	6' x 14' DD	Weight	Pre-Screen	22.6 gpm
Top Deck Media	Tapered Bars	RPM	970		Side Discharge Conveyor	14.6 gpm
Bottom Deck Media	Wire Mesh	Recirculation Conveyor - Optional	26"		Discharge Conveyor	22.2 gpm
Maximum RPM	1050				Diesel Tank Capacity	157 gal
					Hydraulic Tank Capacity	172 gal

OPTIONS AVAILABLE

2 - Deck screen with recirculation conveyor
 Pan feeder under crusher
 Work Lights

Main discharge conveyor variable speed control
 Hopper extensions
 Dust suppression system with water pump

Main discharge conveyor self-cleaning magnet
 Belt scale