



LIBERTY[®] JAW CRUSHER

Demanding Applications Need a Jaw Crusher Designed to Handle Tough Production Requirements.

FEATURES

- » Bolted, non-welded frame construction with premium quality castings and components.
- » Hydraulic wedge adjustment allows for push button control of closed side settings.
- » Aggressive nip angle ensures the jaw consistently processes material and maintains capacity throughout liner life.
- » Mid-mount frame ensures compact installation.

APPLICATIONS



Ore/Hard
Rock Mining

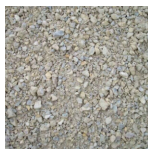

Quarried
Stone



River
Gravel



Recycle
Concrete

Wheeled 
Stationary 

Rock Face to Load Out[®]



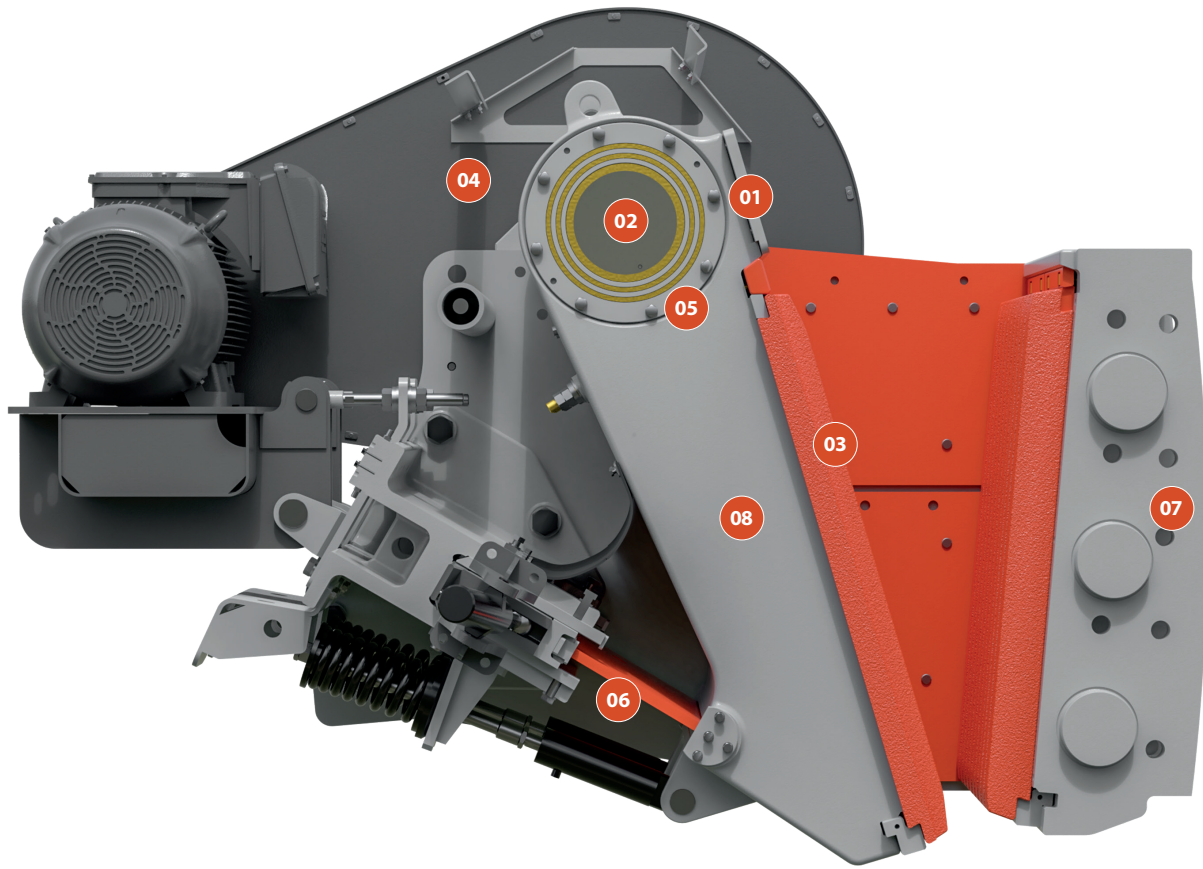

01/ REPLACEABLE BARREL LINER

Easily replaced and designed to protect the bearings and pitman housing.

02/ HIGH STRENGTH ECCENTRIC SHAFT

This hardest working component is precision CNC-machined for proven high strength and reliability.

03/ QUARRY DUTY JAW DIES

Offering different liner configurations expands the application window for the crusher.

04/ SOLID CAST, HIGH INERTIA FLYWHEELS

Optimized design to generate the crushing force required for the toughest and hardest materials.

05/ SPHERICAL ROLLER INBOARD/ OUTBOARD BEARINGS

Ensures the maximum performance providing the lowest cost of ownership.

06/ HIGH STRENGTH TOGGLE PLATE

Provides the correct protection of the crusher to ensure performance and long term durability.

07/ FRONT AND REAR CAST END FRAMES

Cast structural components, including end frames and a one-piece pitman, for a high strength strength machine.

08/ ONE-PIECE CAST PITMAN

High strength solid casting.

HIGHLIGHTS

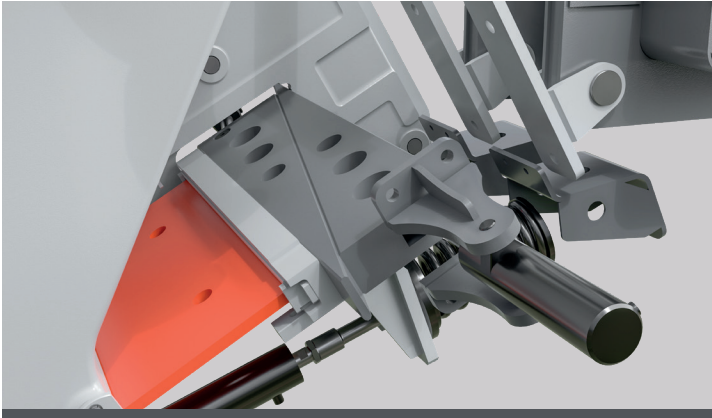

HYDRAULIC WEDGE ADJUSTMENT

- » Single push button hydraulically allows operators to adjust closed side settings (Manual shim available).

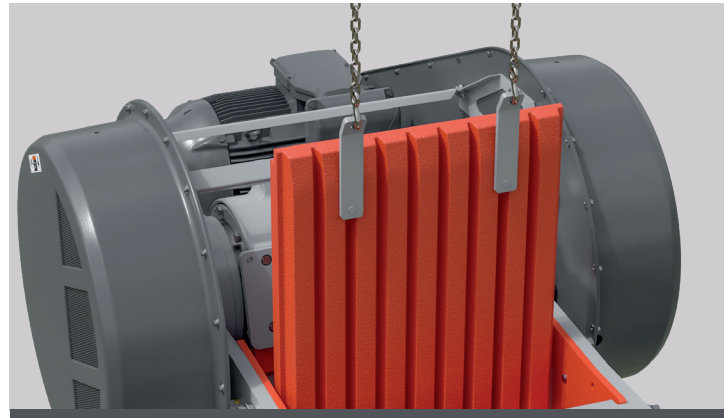

JAW DIE LIFTING POINTS

- » Integrated into the dies versus unsafe welded options, which can break from the dies.

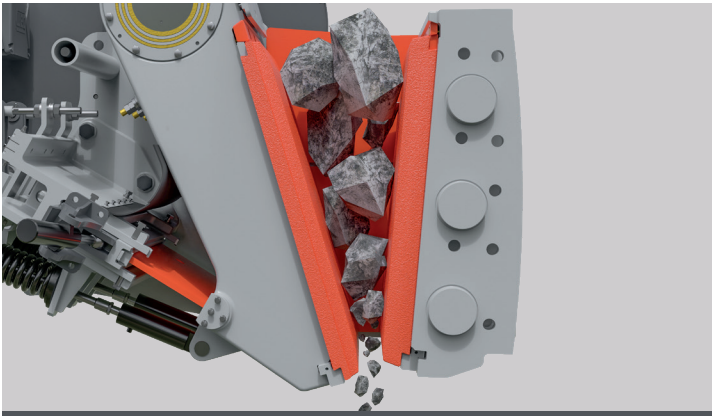

AGGRESSIVE NIP ANGLE

- » Jaw consistently processes material and maintains strong capacity through liner life.



PITMAN TOE PROTECTION

- » Replaceable component for protection and to eliminate long periods of downtime for re-machining.

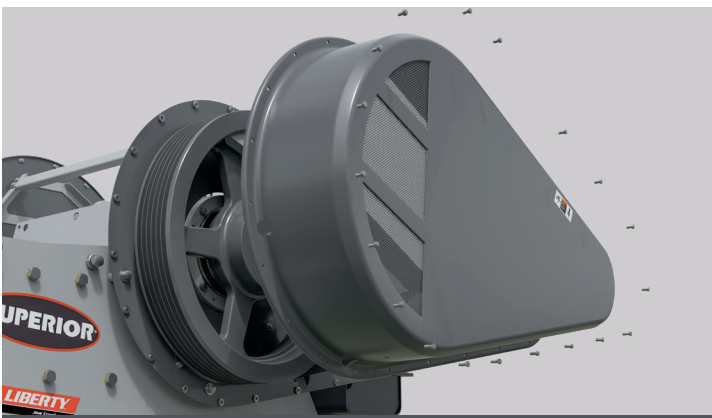

COMPOSITE DRIVE GUARD

- » Designed for a single crew member to remove guarding for simplified access to drive.

**2-YEAR/
6000 HR
WARRANTY**

SPECIFICATIONS

LIBERTY JAW GENERAL SPECIFICATIONS

Model	Weight		Feed Opening		CSS		Capacity		Speed	Max. Feed Size		Power	
	kg	lbs	mm x mm	inch x inch	mm	inch	mtph	stph	rpm	mm	inch	kW	hp
2055B	16,500	36,400	510 x 1,400	20 x 55	40 - 130	1.6"-5.1"	90-400	100-440	260	406	16.0	110	150
2436B	14,050	31,000	600 x 900	24 x 36	60-160	2.4"-6.3"	110-360	120-369	300	488	19.2	75	100
2842B	15,700	34,600	710 x 1,070	28 x 42	70 - 200	2.75"-8.00"	150-500	165-550	280	569	22.4	110	150
3043B	22,300	49,200	760 x 1,100	30 x 43	80-200	3.2"-8"	180-620	200-680	270	610	24.0	110	150
3055B	26,950	59,000	760 x 1,400	30 x 55	70-200	2.75" x 8.00"	240-780	265-855	260	610	24.0	160	200
3255B	31,500	69,445	820 x 1,400	32 x 55	100-200	4"-8"	320-800	353-880	250	650	25.6	150	200
3448B	28,000	62,000	860 x 1,220	34 x 48	70-200	2.75" x 8.00"	170-560	185-615	230	690	27.2	160	200
3951B	42,000	92,600	1,000 x 1,300	39 x 51	100-200	4"-8"	290-880	320-970	220	800	31.5	160	200
4355B	52,500	115,800	1,100 x 1,400	43 x 55	150-250	6"-10"	400-900	440-990	220	875	34.4	200	300
4763B	71,250	157,100	1,200 x 1,600	47 x 63	150-270	6"-10.5"	550-1,100	605-1,210	220	960	37.6	250	350
5978B	135,000	297,000	1,500 x 2,000	59 x 78	200-300	8"-12"	700-1,450	770-1,595	200	1,200	47.2	400	500

PERCENT PASSING FOR A GIVEN CLOSED SIDE SETTING - AVERAGE FEED MATERIAL (12-14 work index)

inch	mm	1.5"	2"	2.5"	3"	3.5"	4"	5"	6"	7"	8"	10"	11"	12"
		(38mm)	(50mm)	(63mm)	(76mm)	(88mm)	(101mm)	(127mm)	(152mm)	(177mm)	(203mm)	(254mm)	(279mm)	(304mm)
18	457												100%	100%
16	406											100%	98	94
14	355											98	90	83
12	304										100%	84	77	70
10	254								100%	100%	88	70	64	58
8	203							100%	94	80	70	56	51	47
7	177							94	82	70	61	49	45	41
6	152					100%	100%	82	70	60	53	42	38	35
5	127				100%	99	87	70	58	50	44	35	32	29
4	101		100%	100%	92	80	70	56	47	40	35	28	25	23
3	76	100%	95	83	70	60	53	42	35	30	27	21	19	18
2.5	63	95	85	70	59	50	44	35	29	25	22	18	16	15
2	50	85	70	57	48	40	35	28	24	20	18	14	13	12
1.5	38	69	52	42	35	30	26	21	18	15	14	11	10	9
1	25	44	34	28	23	20	17	14	12	10	9	7	7	6
0.75	19	32	25	21	18	15	13	11	9	8	7	5	5	5
0.5	12	22	18	15	12	10	9	7	6	5	5	4	4	3
0.25	6	12	10	8	6	5	5	4	3	3	2	2	2	1

Projected crusher capacities are based on a material having a work index of 12-14, with a bulk density of 100 lbs/ft³ (1.6 mt/m³). The feed grading must have less than 10% passing the crusher setting. The crusher drive assemblies are to be maintained in good working order with the ability to apply all available horsepower without drive belt slippage. Plant installation to ensure the crusher is able to operate continuously consuming the FLA rating of the motor(s) with the equipment able to accept and discharge material freely. For secondary cone crusher applications to be used in closed circuit applications consult Superior for capacity adjustments.

MULTIPLE LINER CONFIGURATIONS

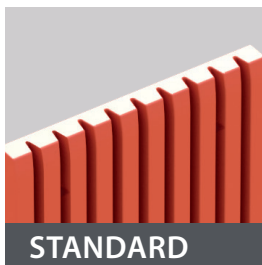

STANDARD

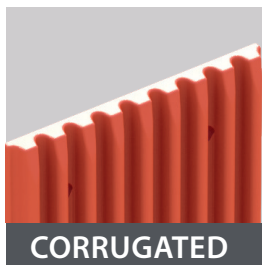

CORRUGATED



SHARP TOOTH



BELLIED-FILLED

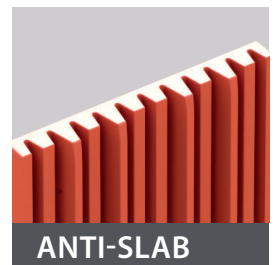

ANTI-SLAB